

NO. 742 SHELF BRACKET

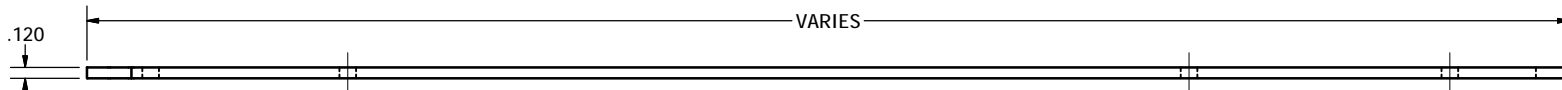

TOP VIEW

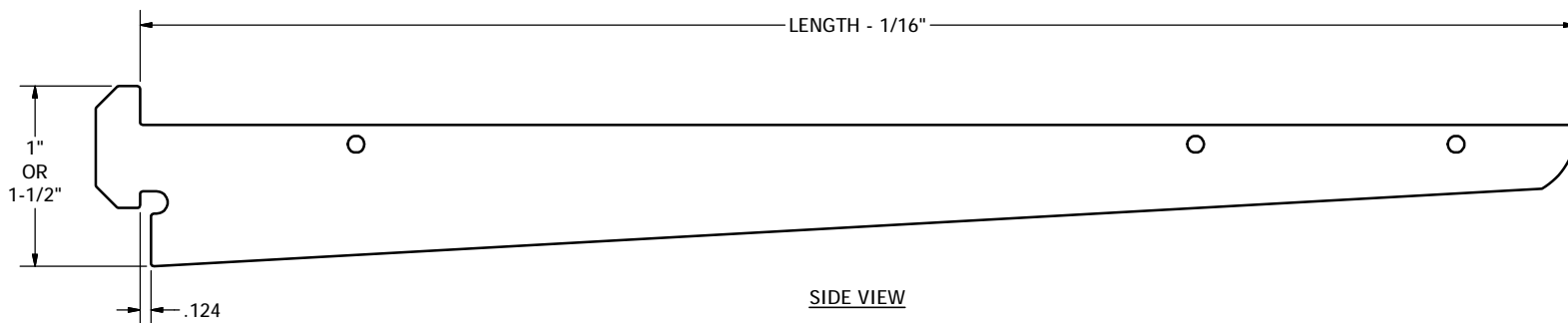

SIDE VIEW

TABLE			
PART NUMBER	LENGTH	PACKED/CTN.	WT./CTN.
742-8	8"	24	6 LBS.
742-10	10"	24	8 LBS.
742-12	12"	24	10-1/2 LBS.
742-14	14"	24	14-1/2 LBS.
742-16	16"	24	16-1/2 LBS.
742-18	18"±1-1/2"	12	20-1/2 LBS.

APPLICATION:

FOR USE WITH CONCEALED/RECESSED/"T" STANDARDS AND GLASS OR WOOD SHELVES.
SEE PAGE 2.6 FOR SHELF REST CLIPS.

FEATURES:

1/8" THICK TEMPERED STEEL.

STOCK FINISH:

BRILLATONE
(SATIN ZINC)
AND POLISHED CHROME.

1.- BREAK ALL SHARP EDGES AND REMOVE ALL BURRS.

NOTE: UNLESS OTHERWISE SPECIFIED:

UNLESS OTHERWISE SPECIFIED, DIMENSIONS ARE INCHES. TOLERANCES ARE: FRACTIONS: DECIMALS: ANGLES: +/- 1/32 .xx +/- .01 +/- 1/2 .xxx +/- .005	CUSTOMER			
	APPROVALS DATE DRAWN FLP 9/22/2015			
SEE NOTES	CHKD.		TITLE	
	APVD.		NO. 742 SHELF BRACKET	
	EQCB No.		SIZE B	DWG. No. NO.742
DO NOT SCALE DRAWING	N/A		SCALE: N.T.S.	SHEET: 1 OF 1

THIS DRAWING IS THE EXCLUSIVE PROPERTY OF REVE STORE EQUIPMENT CO. WHO HOLDS AND MAINTAINS FULL COPYRIGHT PROTECTION UNDER FEDERAL AND STATE LAW. THIS DRAWING CANNOT BE DUPLICATED, PHOTOCOPIED, DIGITALLY TRANSFERRED, OR REPRODUCED WITHOUT THE EXPRESS WRITTEN CONSENT OF REVE STORE EQUIPMENT CO. COPYRIGHT 2012, 2011, 2010, 2009, 2008, 2007, 2006, 2005, 2004, 2003, 2002. ALL RIGHTS RESERVED.