

## Center Hung Pivot

- Non-Handed
- Top, header mount
- Bottom, base plate mount
- Easy installation tilt on bearing and bearing pin.
- Use with 1-3/4" minimum door thickness.
- Adjustable floor to door clearance 3/16" to 3/4".
- Maximum door load 300 pounds
- Vertical adjustment range 3/16", with positive locking

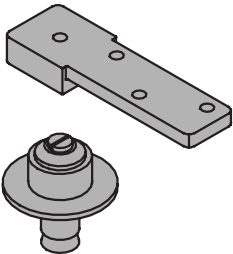

### Plated Finishes *brass*

US Number	US3	US4	US10	US10B	US26	US26D
BHMA Number	605	606	612	613	625	626

### Painted Finishes *brass*

US Number	SP4	SPI0	SP28	SP313	SPBLK
BHMA Number	706	691	689	695	622

Meets ANSI/BHMA A156.4 C07032

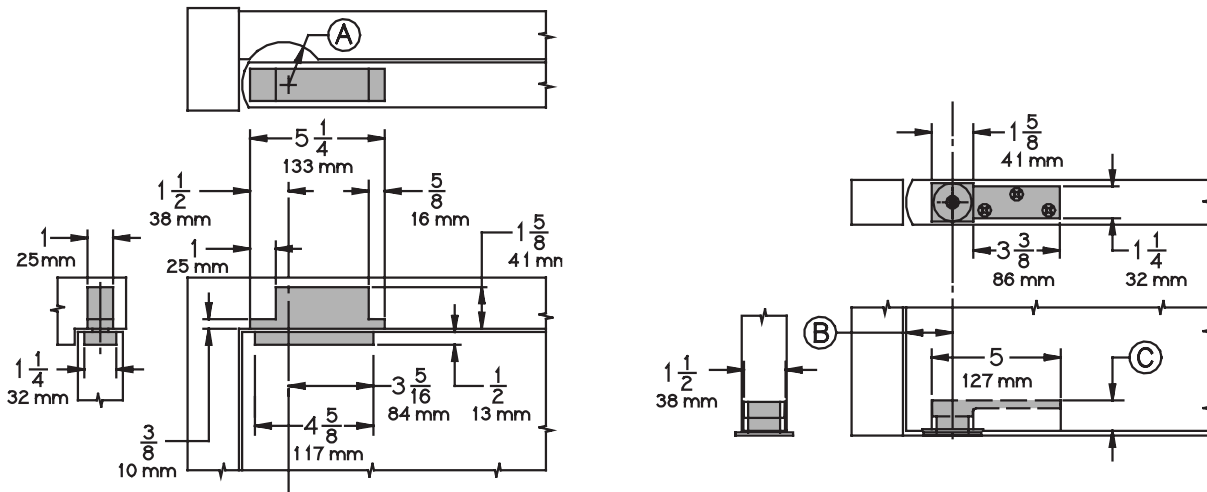

- Radius Stop (A) to clear heel of door edge.
- Pivot distance (B) 1-3/4" (44mm) minimum from jamb to centerline of pivot pin. Radius heel edge of door, 1-5/8" (41mm) minimum recommended.
- Clearance from bottom edge of door to floor mounting surface is adjustable from 3/16" (5mm) to 3/4" (19mm) by varying the depth of the mortise (C) in the bottom of the door, refer to Chart D. Consult factory when clearance is over 3/4" (19mm).

**Table D**

Clearance	Depth of Mortise
3/16" (5mm)	1-3/16" (30mm)
3/8" (10mm)	1" (25mm)
1/2" (13mm)	7/8" (22mm)
5/8" (16mm)	3/4" (19mm)
3/4" (19mm)	5/8" (16mm)