

Guide to Maintenance, Troubleshooting, and Repair



3", 3 x 6", 4½" AND 6"
VACUUM CUPS
(Not all cups are pictured)

**THE ORIGINAL
& TRUSTED NAME
IN VACUUM LIFTING
EQUIPMENT**

Wood's Powr-Grip Co., Inc.
908 West Main - P.O. Box 368
Laurel, Montana 59044 U.S.A.
406.628.8231 (phone)
406.628.8354 (fax)

800.548.7341
www.powrgrip.com



Products are manufactured under an
ISO 9001 quality management system

Wood's Powr-Grip products are sold
through authorized dealers.

General Maintenance

For maximum reliability, **INSPECT THE VACUUM CUP REGULARLY**: Make sure the air filter is in place; if not, discontinue use until the filter is replaced. Examine the plunger and cylinder for cracks or other damage. Examine the face of the vacuum pad for excessive glaze (a polished, glossy appearance) and for cuts or roughness on the sealing edge. Periodically test the cup for excessive leakage, sluggishness in plunger action or radical changes in the number of strokes needed to keep the red line hidden. If the cup does not function normally, review the Troubleshooting Guide (overleaf) to determine what corrective action is needed.

To **CLEAN THE VACUUM PAD**, remove the air filter from the pad face. Use a clean sponge or lint-free cloth to apply soapy water or another mild cleanser to the cup face. **Never use solvents or rubber conditioners as a cleaning agent** (see WARNINGS). To prevent liquid from contaminating the pump during cleaning, hold the cup face-down or cover the suction inlet in the filter recess. Wipe all residue from the pad face and allow the cup to dry. Then reinstall the air filter.

Inspecting and Testing the Cup for Leakage

To **INSPECT THE SEALING EDGE** of the vacuum pad for roughness or foreign material, slowly draw your finger along the entire sealing edge. Examine the sealing edge for cuts by bending the edge of the pad face towards you to create a hump, turning the vacuum cup as necessary. If cuts or cracks are present in the sealing edge, a V-shaped gap will appear. Any pad that exhibits a gap or excessive roughness in the sealing edge must be replaced.

To **LEAK-TEST THE VACUUM CUP**, attach it to a clean, smooth, scratch-free piece of glass or metal for approximately 2 hours. The red line on the plunger serves as a vacuum indicator: If the red line *does not* appear during the test period, the cup is usable; if the red line *does* appear, perform general maintenance and repeat the test. If the problem persists, check the Troubleshooting Guide (overleaf) to identify possible causes and appropriate corrective actions. If these measures do not restore the cup to normal performance, contact the Wood's Powr-Grip Customer Service department or an authorized dealer for assistance.

Environmental conditions can affect product performance and longevity; consult the product instructions on www.powrgrip.com or contact a Technical Sales Representative for more information.
Based on product information at time of publication.

PARTS AND ASSEMBLY

Ref. Stock #	Description
1. 60024	Air Filter
2.	Release Tab
3.	Plunger
4.	Red Line
5. 90111	Pump
6. 49386T	Vacuum Pad, 6" Dia., Concave Face
49396T	Vacuum Pad, 6" Dia., Concave Face (for Rigid Handle)
49426T	Vacuum Pad, 6" Dia., Flat Face
7. 10020	Screw, 10-32 x 1/2"
8. 50220	Accessory Mount, Aluminum (for Tie-Down or Flip Handle)
50210	Accessory Mount, Aluminum, 1/4-20 Stud
9. 50230	Rigid Handle
10. 15790	T-Handle (fits on 1/4-20 stud)
11. 50100	Tie-Down
12. 50102	Flip Handle
13. 10156	Screw, 10-32 x 1/4"
14. 60118	Accessory Mount, 1/4-20 Stud
15. 60116	Handi-Grip Handle (for 3" x 6" pads)
50205	Handi-Grip Handle (for 4 1/2" x 6" pads)
16. 49365T	Vacuum Pad, 3 x 6", Concave Face
17. 49326T	Vacuum Pad, 3" Dia., Concave Face
18. 10008	Screw, 10-32 x 3/8"
19. 60181	Accessory Mount, Polycarbonate, 1/4-20 Insert
60180	Accessory Mount, Polycarbonate, 1/4-20 Stud
20. 49345T	Vacuum Pad, 4 1/2" Dia., Concave Face
21. 10024	Screw, 10-32 x 5/8"
22.	Cylinder
23.	Check Valve (Rubber)
24.	Retainer
25.	Button
26.	U-Cup
27.	Plunger Assembly
28.	Valve Stem
Not Shown	
29306MM	Pad Cover, 3"
29308	Pad Cover, 4 1/2"
29312	Pad Cover, 6"
28502	Plunger Lube

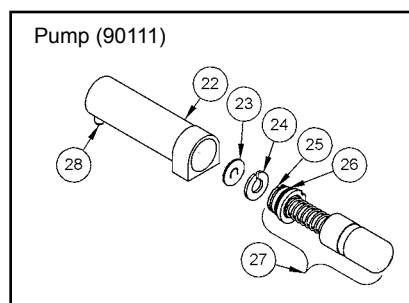
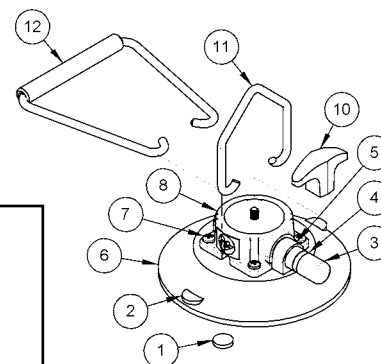
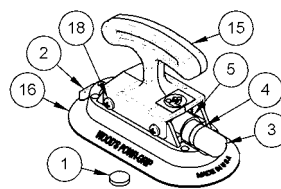
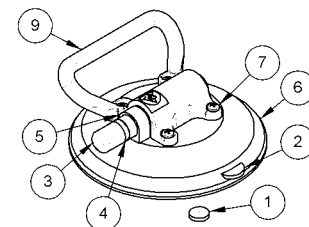
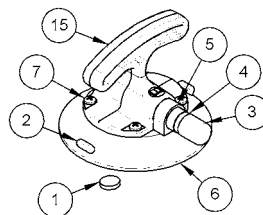
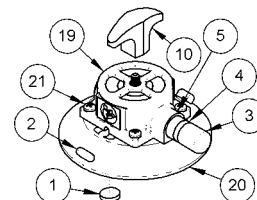
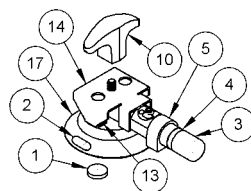

TROUBLESHOOTING GUIDE

PROBLEM	CAUSE	CORRECTION
Slow leakage	Cuts on sealing edge	Replace vacuum pad.
	Dirt or lint inside pump	Wipe inside of handle with a soft cloth. Check for contamination on U-cup or button.
	Dry pump	Apply a light coating of plunger lube inside handle.
	Scratches inside cylinder (between mid-point and closed end)	Replace handle.
	Contaminated pad face	Clean vacuum pad.
Severe leakage	Gouges or cuts on sealing edge	Replace vacuum pad.
	Damaged pump	Replace pump.
Jammed or sluggish pump	Dry pump	Apply a light coating of plunger lube to U-cup.
	Obstructed valve stem	Remove obstruction (through suction inlet behind air filter).
	Severe contamination	Clean plunger assembly and inside of cylinder.
Pad slips when attached	Contaminated mounting surface	Wipe surface clean. If necessary, wash and allow to dry.
	Contaminated pad face	Clean vacuum pad.
	Excessive glaze or wear on pad face	Replace vacuum pad (at least once every two years).
More than 10 strokes needed to apply	Any of the above	Perform general maintenance.
	Dirt or lubricant on check valve	Remove, clean and reinstall plunger assembly, retainer and check valve as directed in Disassembly and Assembly sections (on facing page).

Disassembly Procedures



Remove Plunger Assembly from Cylinder

Grasp the head of the plunger assembly and pull it straight out from the cylinder. Be careful to keep the plunger assembly clean and free from contaminants. It is advisable to cover the plunger assembly with a clean, lint-free towel when it is not in the cylinder.



Remove Handle/Mount and Cylinder from Vacuum Pad

Remove the screws that attach the handle/mount to the pad (2 screws on 3" [8 cm] diameter models, 4 screws on other models). Separate the handle/mount from the pad. Carefully remove the valve stem from the rubber nipple on the pad by gently pulling on the cylinder and twisting it back and forth.



Remove Retainer and Check Valve from Cylinder

Being careful not to scratch the inside of the cylinder, remove the retainer and check valve using a hooked scribe or similar tool. With a soft, lint-free cloth, carefully clean these parts, as well as the plunger assembly, paying particular attention to the U-cup and button. Wrap a small dowel or rod with a soft, lint-free cloth and gently wipe the inside of the cylinder, to make sure it is clean and dry (lubricant-free).

Assembly Procedures



Inspect Cylinder and Reinstall Check Valve and Retainer

Carefully examine the inside of the cylinder for scratches and contaminants, using a flashlight for illumination. Scratches between the mid-point and the closed end of the cylinder can cause leakage. Scratches near the open end of the cylinder rarely present a problem. Make sure that no lubricant remains inside the cylinder. Drop the check valve inside the cylinder so that it lies flat against the closed end. Using a dowel or other tool that will not scratch the sides of the cylinder, push the retainer all the way into the cylinder to hold the check valve securely in place.



Reinsert Plunger Assembly into Cylinder and Pump into Vacuum Pad

Carefully apply a light coating of lubricant around the U-cup. Plunger lube is recommended and available in appropriate quantities by contacting Wood's Powr-Grip Customer Service. **Do not use improper lubricants in the pump.** While making certain the button, check valve and retainer remain free of lubricant, insert the U-cup end of the plunger assembly into the cylinder, and gently push until the plunger assembly bottoms out. Operate the plunger to spread the lubricant, thoroughly coating the inside of the cylinder by twisting the plunger as it moves. Lightly lubricate the valve stem of the assembled pump, and insert the valve stem into the pad nipple.



Attach Handle/Mount to Vacuum Pad

Carefully place the handle/mount over the pump and onto the pad, and align the screw holes. The pump should fit snugly under the mount but should not bind. Making sure the valve stem remains inserted in the pad nipple, reinstall the handle/mount screws and tighten. Now the cup is assembled and ready for testing.



WARNINGS

Wood's Powr-Grip has taken great care to produce the most reliable vacuum-operated handling and mounting devices available. Nevertheless, mistreatment or misuse may damage a vacuum cup or otherwise create conditions which could cause the vacuum cup to fail, resulting in an unexpected release. The following warnings are offered to help users avoid most potential hazards.

Failure to observe WARNINGS could damage the cup or the load, or cause injury to the user.

- Do not use the cup with loads that exceed the load capacity.
- Do not use the cup to support a person.
- Do not use the cup to support loads which could injure people if the cup disengages unexpectedly.
- Do not place the pad face against surfaces which could damage the sealing edges.
- Avoid conditions that could cause the cup to slip or to disengage prematurely, such as: contaminants, cuts or scratches in the pad face or mounting surface; applying the cup to porous materials; or applying pressure against the pad edge.
- Do not use the cup when the red line is visible. If the red line reappears frequently, discontinue use and follow the instructions for general maintenance and testing.
- Do not allow anything to interfere with free movement of the plunger while the cup is attached. This could prevent the red line from warning the user of vacuum loss.
- Do not touch any release tab while using the cup.
- Do not leave the cup in use and unattended.
- Do not use harsh chemicals (such as solvents or gasoline) or unauthorized rubber cleaners and conditioners to clean the cup. See www.powrgrip.com for more information.