



The options available on Truth Hardware's 9200 Series Sash Locks are virtually endless.

- There are bases with or without alignment lugs which are helpful in preventing side shift of the sash (See Truth Tip #1).
- There are various mounting hole patterns from which to choose, which will ensure that your hardware is located in the most efficient location for optimum holding power (See Truth Tip #5).
- A variety of locking cams are available that help to pull meeting rails tightly together and will produce a better seal of the sash at the head and sill to help decrease air infiltration. Another reason for optional cam sizes is to help avoid potential interference created when the cam extends out to far. Refer to the following drawings to find the one which best meets your requirements.
- Based on window design, and the space allowed for mounting the window hardware – some window systems are better suited for narrower keepers, or even face-mounted varieties. The 9200 Series has a number of Top Mount, and Face Mount keepers to choose from.

LOGO OPTIONS: For that “personalized touch”, Truth’s 9200 Series Check Rail Locks are capable of accepting your company’s name or logo. Truth’s logo reproduction process is an attractive way of highlighting your company signature. For further details on where your company’s logo would appear, please refer to the following drawings.

WARRANTY:
Protected under the terms of the “Truth Warranty for Window & Door Manufacturers & Authorized Distributors”. Refer to Truth’s Terms & Conditions for further details.

MATERIAL: High-pressure, corrosion-resistant, die-cast zinc.

FINISH: Electrostatically applied, durable coatings that provide excellent resistance to chipping, scratching and corrosion while maintaining color



stability for years in direct sunlight. Please refer to Truth’s Color Chart for examples of Truth’s most popular finish options. Truth also offers a wide range of decorative “plated” finishes – contact Truth for additional information on availability of these finishes on specific product lines.

ORDERING INFORMATION:

1. Choose the 9200 Series Cam Lock style desired (specify by part number).
2. Specify finish number.
3. Specify Keeper to be ordered.

RECOMMENDED SCREWS:

Types of screws required determined by material of profile used (sold separately). For additional information on screw selection - see Truth Tips.

TRUTH TIPS:

1. A lock with pick-resistant alignment nibs should be used whenever possible. A lock without nibs should be chosen when the lugs cause interference with divided light grills or other window features.
2. A lock with a small cam should be used when the larger sweep radius of the .125” (3.2 mm) pull-in cam causes interference with the glazing or other areas of the profile. A face-mounted keeper is usually required.
3. When two locks are used on one window, the placement of each lock, with respect to its keeper, becomes very critical to maintain a constant weatherseal on all sides of the window and to insure that each lock engages properly with its keeper.
4. For accurate hardware placement in vinyl or metal applications, pre-drilling of the window profile is recommended.

5. For vinyl window applications, mounting screws should pass through two PVC walls, or one PVC wall and one insert wall. For this reason, it may be necessary to use a longer screw than is recommended.

6. For metal window profiles, Truth recommends stainless steel machine screws. However, in most applications, stainless steel sheet metal screws will provide adequate holding power.

INCLUDE TRUTH SPECS ON YOUR NEXT WINDOW PROJECT

Window check rail locks shall be included which will increase both security and weather seal tightness. The lock must provide easy operation and positive locked feel.

Window check rail locks will be of internal cam design to provide optimum pull-in to aid in sealing the meeting rails. The lock and accompanying keeper will prevent misalignment during locking. The lock and keeper shall be constructed of high pressure zinc alloy die castings.

Window locks shall be 9200 Series locks as manufactured by Truth Hardware.

FIG. 1 SASH LOCK AND KEEPER

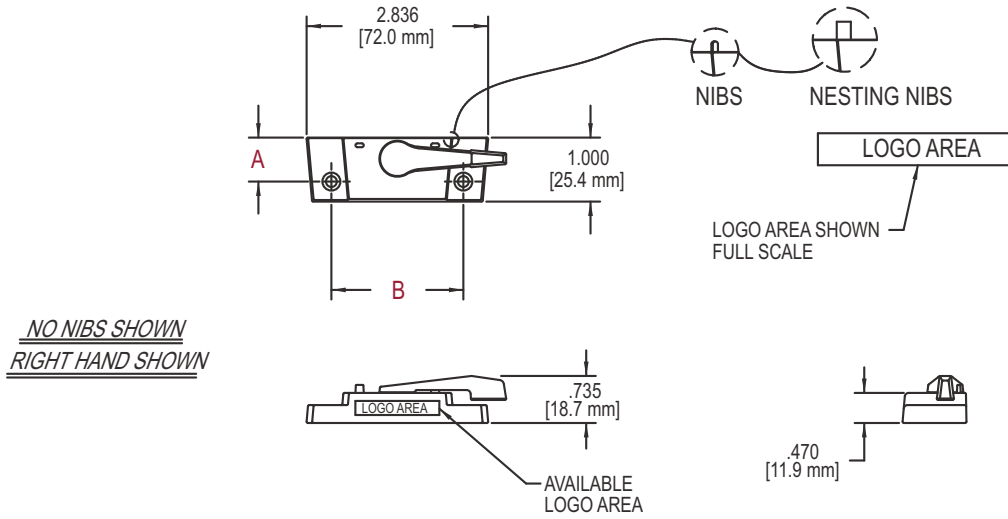

PART NUMBER	"A" DIMENSION	"B" DIMENSION	HANDING		NIBS			RECOMMENDED SCREWS *	CAM REACH
			RH	LH	NO NIBS	NIBS	NESTING NIBS		
A09200400	0.390 (9.9mm)	2.250 (57.2mm)	X		X			# 8 SCREW	0.06 (1.5mm)
A09200401	0.390 (9.9mm)	2.250 (57.2mm)	X			X		# 8 SCREW	0.06 (1.5mm)
A09200402	0.437 (11.1mm)	2.062 (52.4mm)	X				X	# 6 SCREW	0.06 (1.5mm)
A09200407	0.687 (17.4mm)	2.062 (52.4mm)	X			X		# 6 SCREW	0.06 (1.5mm)
A09200409	0.687 (17.4mm)	2.062 (52.4mm)	X		X			# 6 SCREW	0.06 (1.5mm)
A09200411	0.719 (18.3mm)	2.156 (54.8mm)	X		X			# 8 SCREW	0.06 (1.5mm)
A09200412	0.437 (11.1mm)	2.062 (52.4mm)	X		X			# 6 SCREW	0.06 (1.5mm)
A09200416	0.437 (11.1mm)	2.062 (52.4mm)	X		X			# 6 SCREW	NO PULL-IN
A09200417	0.687 (17.4mm)	2.062 (52.4mm)	X		X			# 6 SCREW	NO PULL-IN
A09200420	0.687 (17.4mm)	2.062 (52.4mm)	X				X	# 6 SCREW	0.06 (1.5mm)
A09200427	0.687 (17.4mm)	2.062 (52.4mm)	X		X			# 6 SCREW	0.06 (1.5mm)
A09200430	0.390 (9.9mm)	2.250 (57.2mm)	X		X			# 8 SCREW	0.06 (1.5mm)
A09200432	0.390 (9.9mm)	2.250 (57.2mm)	X				X	# 8 SCREW	0.06 (1.5mm)
A09200441	0.437 (11.1mm)	2.250 (57.2mm)	X		X			# 8 SCREW	0.06 (1.5mm)
A09200457	0.437 (11.1mm)	2.250 (57.2mm)		X	X			# 8 SCREW	0.06 (1.5mm)
A09200520	0.687 (17.4mm)	2.062 (52.4mm)	X		X			# 6 SCREW	0.06 (1.5mm)
A09200537	0.687 (17.4mm)	2.062 (52.4mm)		X			X	# 6 SCREW	0.06 (1.5mm)
A09200580	0.687 (17.4mm)	2.062 (52.4mm)	X		X			.187 DIA. RIVET	0.06 (1.5mm)
A09200599	0.719 (18.3mm)	2.156 (54.8mm)	X		X			# 6 SCREW	0.06 (1.5mm)

* ALL SCREWS ARE TO BE PHILLIPS FLAT HEAD. (LENGTH AND TYPE TO BE DETERMINED BY PROFILE)

FIG. 2 LOCK/KEEPER COMPATIBILITY TABLES

		"B" DIMENSION (HOLE CENTER TO HOLE CENTER-LOCK TO KEEPER)																		
		LOCKS																		
		A09200400	A09200401	A09200402	A09200407	A09200409	A09200411	A09200412	A09200416	A09200417	A09200420	A09200427	A09200430	A09200432	A09200441	A09200457	A09200520	A09200537	A09200580	A09200599
SURFACE MOUNT KEEPERS	C08924	.60	--	--	--	.60	.93	.65	.65	.90	--	.90	.60	--	.65	.65	.90	--	.90	.93
	C09022	--	.60	--	.90	--	--	--	--	--	--	--	--	--	--	--	--	--	--	--
	C09145	--	.57	--	.87	--	--	--	--	--	--	--	--	--	--	--	--	--	--	--
	C09256	--	.58	--	.87	--	--	--	--	--	--	--	--	--	--	--	--	--	--	--
	C09335	--	--	.64	--	--	--	--	--	--	.89	--	--	.59	--	--	--	.89	--	--
	C09336	.59	--	.64	--	.89	.92	.64	.64	.89	.89	.89	.59	.59	.64	.64	.89	.89	.89	.92
	C09452	--	--	.64	--	--	--	--	--	--	.89	--	--	.59	--	--	--	.89	--	--
	C09717	.57	--	--	--	.87	.90	.62	.62	.87	--	.87	.57	--	.62	.62	.87	--	.87	.90
	C09968	--	.79	--	1.08	--	--	--	--	--	--	--	--	--	--	--	--	--	--	--
	C30022	.60	--	--	--	.89	.93	.65	.65	.90	--	.90	.60	--	.65	.65	.90	--	.90	.93

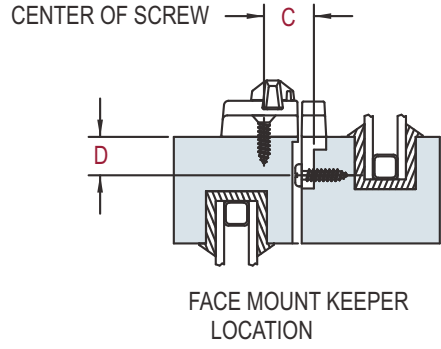
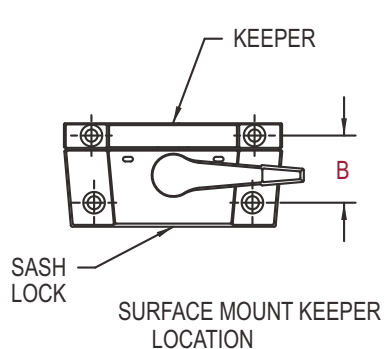

		LOCKS													
		DIMENSION	A09200400	A09200409	A09200411	A09200412	A09200416	A09200417	A09200427	A09200430	A09200441	A09200457	A09200520	A09200580	A09200599
FACE MOUNT KEEPERS	C09062	C	0.63	0.93	0.96	0.68	0.66	0.91	0.93	0.63	0.68	0.68	0.93	0.93	0.96
		D	1.08	1.08	1.08	1.08	1.08	1.08	1.06	1.08	1.08	1.08	1.08	1.08	1.12
	C09312	C	0.40	0.70	0.73	0.50	0.48	0.68	0.70	0.40	0.45	0.45	0.70	0.70	0.73
		D	0.50	0.50	0.50	0.50	0.50	0.50	0.48	0.50	0.50	0.50	0.50	0.50	0.52
	C09391	C	--	--	--	--	--	--	--	--	--	--	--	--	1.08
		D	--	--	--	--	--	--	--	--	--	--	--	--	0.22
	C09659	C	0.65	0.95	0.98	0.70	0.68	0.93	0.95	0.65	0.70	0.70	0.95	0.95	0.98
		D	0.32	0.32	0.32	0.32	0.32	0.32	0.30	0.32	0.32	0.32	0.32	0.32	0.35
	C09697	C	0.65	0.95	0.98	0.70	0.68	0.93	0.95	0.65	0.70	0.70	0.95	0.95	0.98
		D	0.85	0.85	0.85	0.85	0.85	0.85	0.83	0.85	0.85	0.85	0.85	0.85	0.89
	C09906	C	--	--	--	--	--	--	--	--	--	--	--	--	1.08
		D	--	--	--	--	--	--	--	--	--	--	--	--	0.22

FIG. 3 C08924XX KEEPER

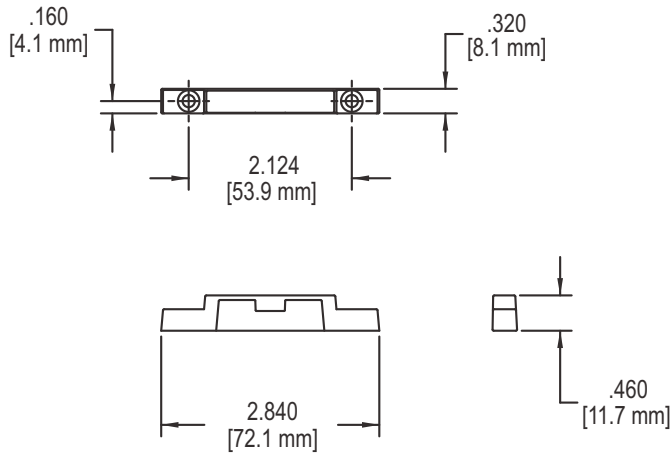

AVAILABLE LOCKS

LOCK PART NUMBER	"B" SEE FIG. 2
A09200400	0.60 (15.2mm)
A09200409	0.60 (15.2mm)
A09200411	0.93 (23.5mm)
A09200412	0.65 (16.5mm)
A09200416	0.65 (16.5mm)
A09200417	0.90 (22.9mm)
A09200427	0.90 (22.9mm)
A09200430	0.60 (15.2mm)
A09200441	0.65 (16.5mm)
A09200457	0.65 (16.5mm)
A09200520	0.90 (22.9mm)
A09200580	0.90 (22.9mm)
A09200599	0.93 (23.5mm)

RECOMMENDED SCREWS:

(QTY 2) #6 PHILLIPS FLAT HEAD SCREWS
(LENGTH AND THREAD TYPE TO BE DETERMINED BY PROFILE)

FIG. 4 C09335XX KEEPER

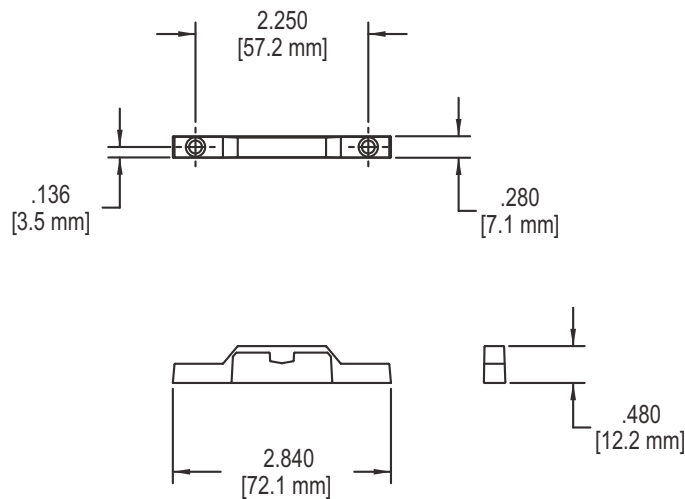

AVAILABLE LOCKS

LOCK PART NUMBER	"B" SEE FIG. 2
A09200402	0.64 (16.3mm)
A09200420	0.89 (22.6mm)
A09200432	0.59 (15.0mm)
A09200537	0.89 (22.6mm)

RECOMMENDED SCREWS:

(QTY 2) #6 SCREW WITH A #5 HEAD
(LENGTH AND THREAD TYPE TO BE DETERMINED BY PROFILE.)

FIG. 5 C09452XX KEEPER

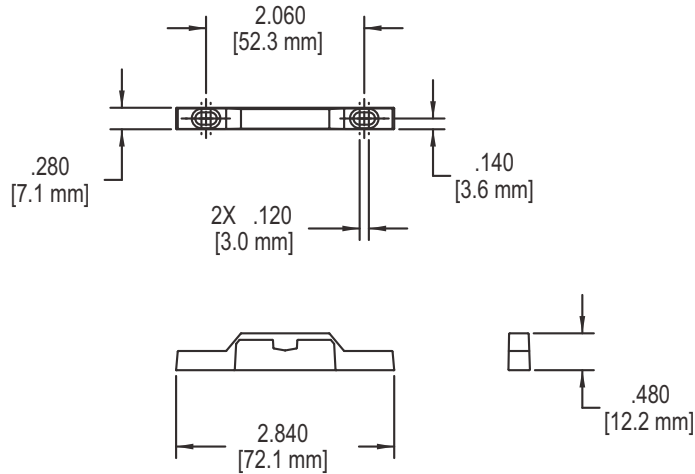

AVAILABLE LOCKS

LOCK PART NUMBER	"B" SEE FIG. 2
A09200402	0.64 (16.3mm)
A09200420	0.89 (22.6mm)
A09200432	0.59 (15.0mm)
A09200537	0.89 (22.6mm)

RECOMMENDED SCREWS:

(QTY 2) #6 SCREW WITH A #5 HEAD (LENGTH AND THREAD TYPE TO BE DETERMINED BY PROFILE.)

FIG. 6 C09717XX KEEPER

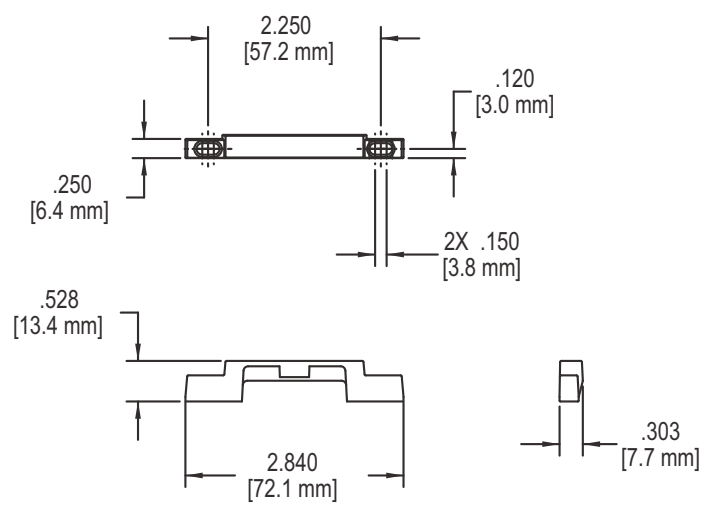

AVAILABLE LOCKS

LOCK PART NUMBER	"B" SEE FIG. 2
A09200400	0.57 (14.5mm)
A09200409	0.87 (22.1mm)
A09200411	0.90 (22.9mm)
A09200412	0.62 (15.7mm)
A09200416	0.62 (15.7mm)
A09200417	0.87 (22.1mm)
A09200427	0.87 (22.1mm)
A09200430	0.57 (14.5mm)
A09200441	0.62 (15.7mm)
A09200457	0.62 (15.7mm)
A09200520	0.87 (22.1mm)
A09200580	0.87 (22.1mm)
A09200599	0.90 (22.9mm)

RECOMMENDED SCREWS:

(QTY 2) #6 PHILLIPS FLAT HEAD SCREWS. (LENGTH AND THREAD TYPE TO BE DETERMINED BY PROFILE.)

FIG. 7 C09336XX KEEPER

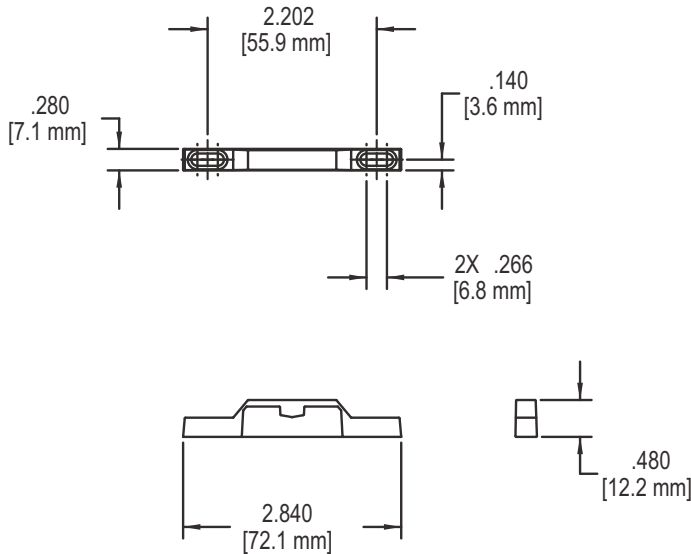

RECOMMENDED SCREWS:

(QTY 2) #6 PHILLIPS FLAT HEAD SCREWS. (LENGTH AND THREAD TYPE TO BE DETERMINED BY PROFILE.)

AVAILABLE LOCKS

LOCK PART NUMBER	"B" SEE FIG. 2
A09200400	0.59 (15.0mm)
A09200402	0.64 (16.3mm)
A09200409	0.89 (22.6mm)
A09200411	0.92 (23.4mm)
A09200412	0.64 (16.3mm)
A09200416	0.64 (16.3mm)
A09200417	0.89 (22.6mm)
A09200420	0.89 (22.6mm)
A09200427	0.89 (22.6mm)
A09200430	0.59 (15.0mm)
A09200432	0.59 (15.0mm)
A09200441	0.64 (16.3mm)
A09200457	0.64 (16.3mm)
A09200520	0.89 (22.6mm)
A09200537	0.89 (22.6mm)
A09200580	0.89 (22.6mm)
A09200599	0.92 (23.4mm)

FIG. 8 C030022XX KEEPER

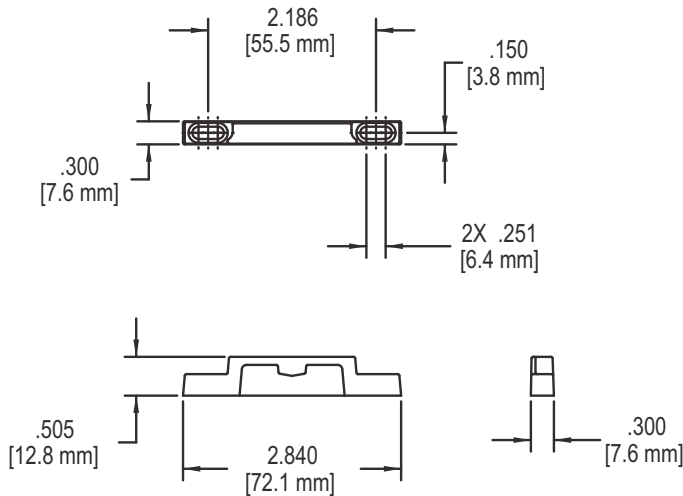

RECOMMENDED SCREWS:

(QTY 2) #6 PHILLIPS FLAT HEAD SCREWS. (LENGTH AND THREAD TYPE TO BE DETERMINED BY PROFILE.)

AVAILABLE LOCKS

LOCK PART NUMBER	"B" SEE FIG. 2
A09200400	0.60 (15.2mm)
A09200409	0.89 (22.6mm)
A09200411	0.93 (23.5mm)
A09200412	0.65 (16.5mm)
A09200416	0.65 (16.5mm)
A09200417	0.90 (22.9mm)
A09200427	0.90 (22.9mm)
A09200430	0.60 (15.2mm)
A09200441	0.65 (16.5mm)
A09200457	0.65 (16.5mm)
A09200520	0.90 (22.9mm)
A09200580	0.90 (22.9mm)
A09200599	0.93 (23.5mm)

FIG. 9 C09022XX KEEPER

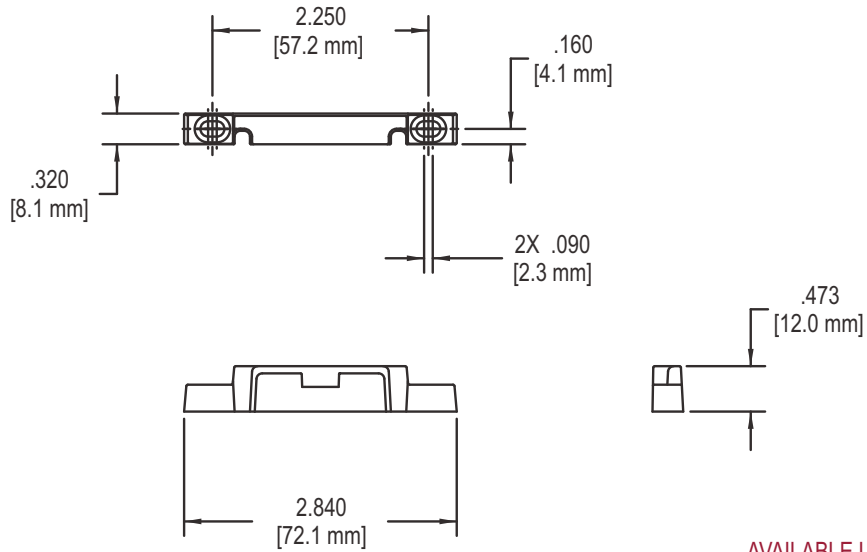

RECOMMENDED SCREWS:

(QTY 2) #8 PHILLIPS FLAT HEAD SCREWS. (LENGTH AND THREAD TYPE TO BE DETERMINED BY PROFILE.)

AVAILABLE LOCKS

LOCK PART NUMBER	"B" SEE FIG. 2
A09200401	0.60 (15.2mm)
A09200407	0.90 (22.9mm)

FIG. 10 C09968XX KEEPER

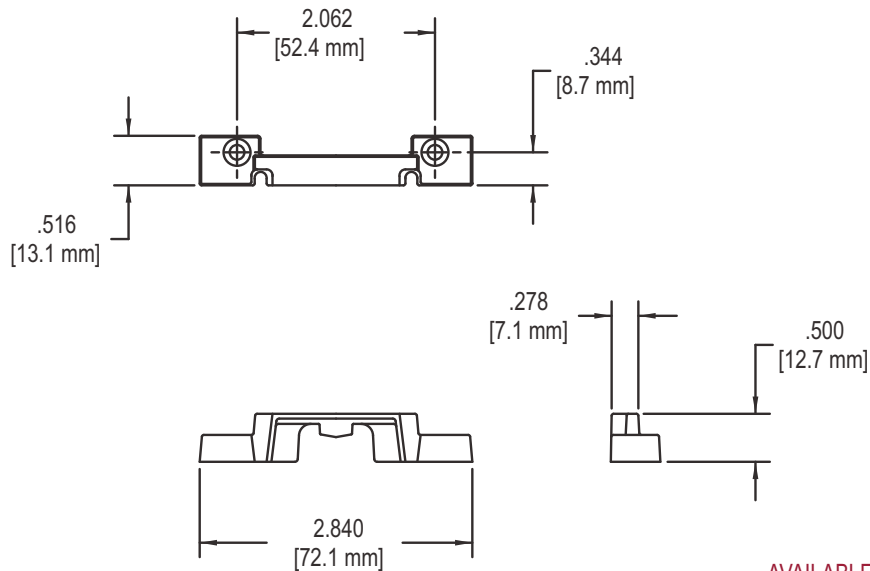

RECOMMENDED SCREWS:

(QTY 2) #6 PHILLIPS FLAT HEAD SCREWS. (LENGTH AND THREAD TYPE TO BE DETERMINED BY PROFILE.)

AVAILABLE LOCKS

LOCK PART NUMBER	"B" SEE FIG. 2
A09200401	0.79 (20.1mm)
A09200407	1.08 (27.4mm)

FIG. 11 C09145XX KEEPER

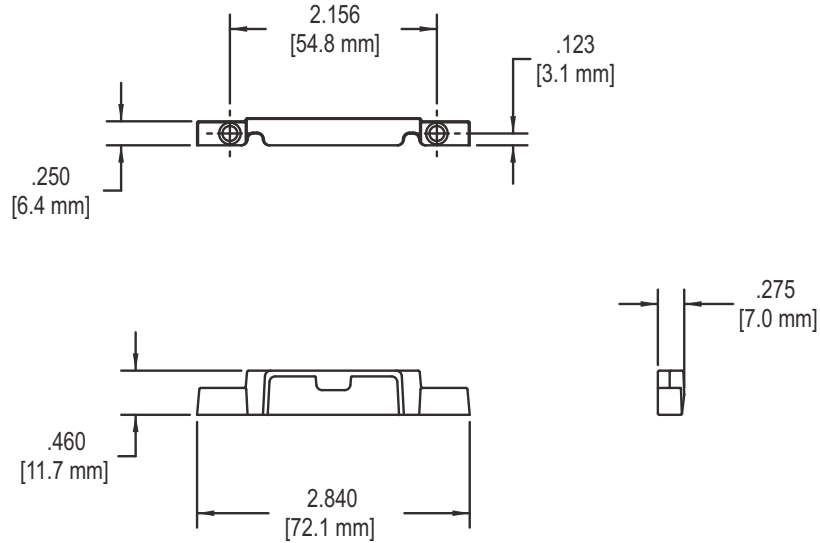

RECOMMENDED SCREWS:

(QTY 2) #8 PHILLIPS FLAT HEAD SCREWS. (LENGTH AND THREAD TYPE TO BE DETERMINED BY PROFILE.)

AVAILABLE LOCKS

LOCK PART NUMBER	"B" SEE FIG. 2
A09200401	0.57 (14.5mm)
A09200407	0.87 (22.1mm)

FIG. 12 C09256XX KEEPER

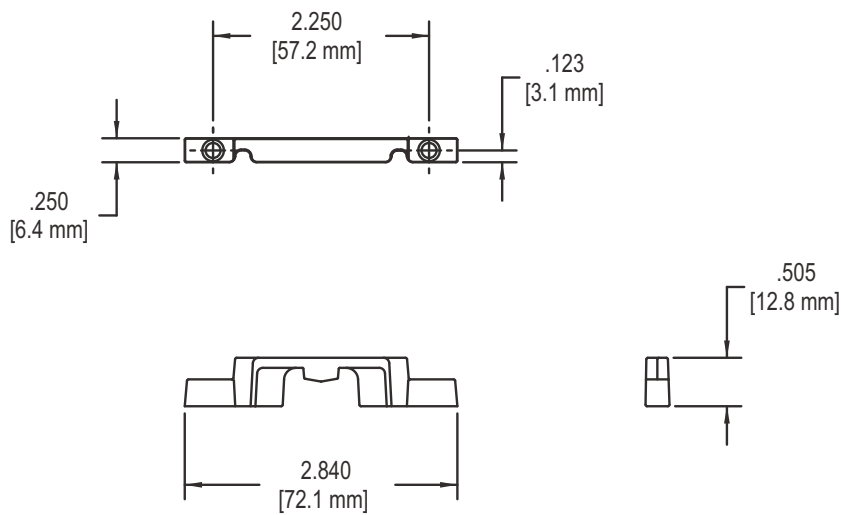

RECOMMENDED SCREWS:

(QTY 2) #6 PHILLIPS FLAT HEAD SCREWS. (LENGTH AND THREAD TYPE TO BE DETERMINED BY PROFILE.)

AVAILABLE LOCKS

LOCK PART NUMBER	"B" SEE FIG. 2
A09200401	0.57 (14.5mm)
A09200407	0.87 (22.1mm)

FIG. 13 C09659XX FACE MOUNT KEEPER

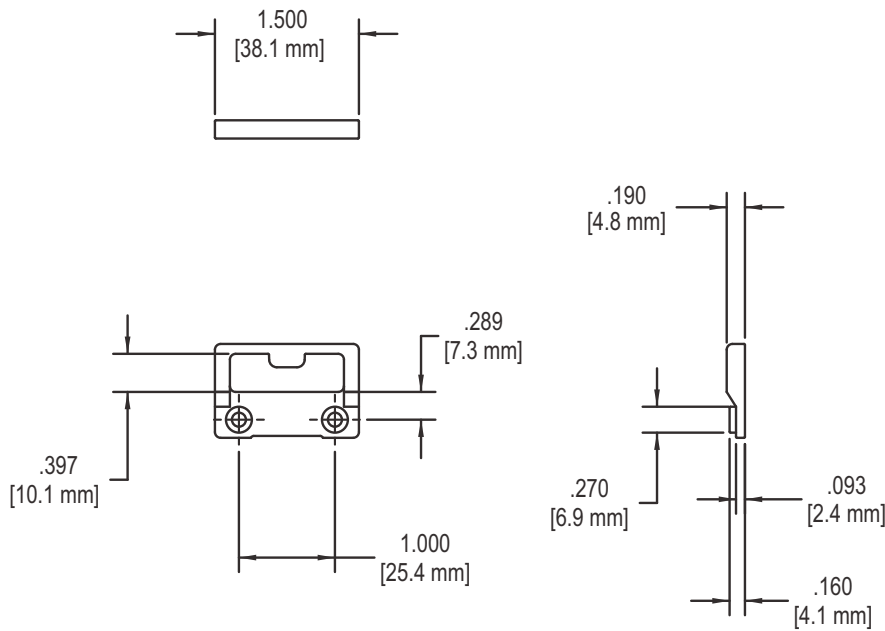

RECOMMENDED SCREWS:

(QTY 2) #6 PHILLIPS FLAT HEAD SCREWS. (LENGTH AND THREAD TYPE TO BE DETERMINED BY PROFILE.)

AVAILABLE LOCKS

LOCK PART NUMBER
A09200400
A09200409
A09200411
A09200412
A09200416
A09200417
A09200427
A09200430
A09200441
A09200457
A09200520
A09200580
A09200599

FIG. 14 C09312XX FACE MOUNT KEEPER

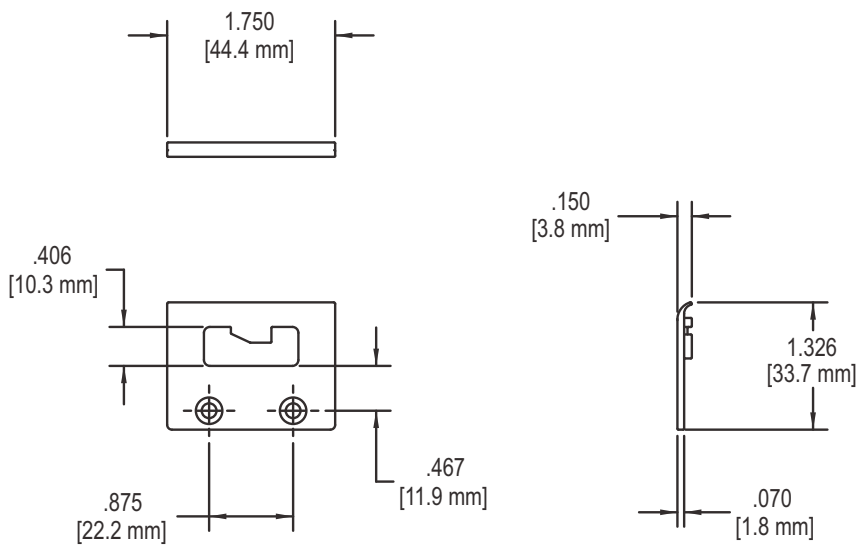

RECOMMENDED SCREWS:

(QTY 2) #6 PHILLIPS FLAT HEAD SCREWS. (LENGTH AND THREAD TYPE TO BE DETERMINED BY PROFILE.)

AVAILABLE LOCKS

LOCK PART NUMBER
A09200400
A09200409
A09200411
A09200412
A09200416
A09200417
A09200427
A09200430
A09200441
A09200457
A09200520
A09200580
A09200599

FIG. 15 C09697XX FACE MOUNT KEEPER

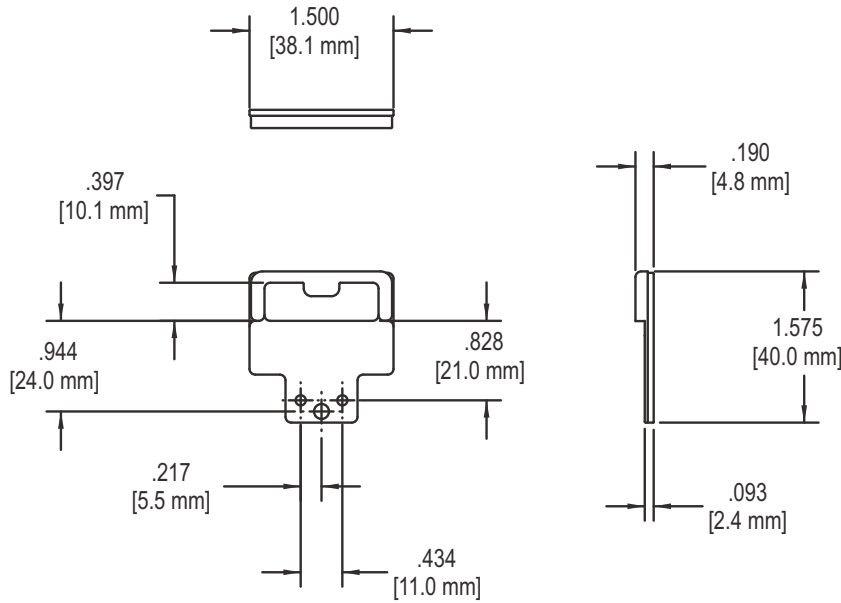

RECOMMENDED SCREWS:

(QTY 2) #6 PHILLIPS FLAT HEAD SCREWS. (LENGTH AND THREAD TYPE TO BE DETERMINED BY PROFILE.)

AVAILABLE LOCKS

LOCK PART NUMBER
A09200400
A09200409
A09200411
A09200412
A09200416
A09200417
A09200427
A09200430
A09200441
A09200457
A09200520
A09200580
A09200599

FIG. 16 C09062XX FACE MOUNT KEEPER

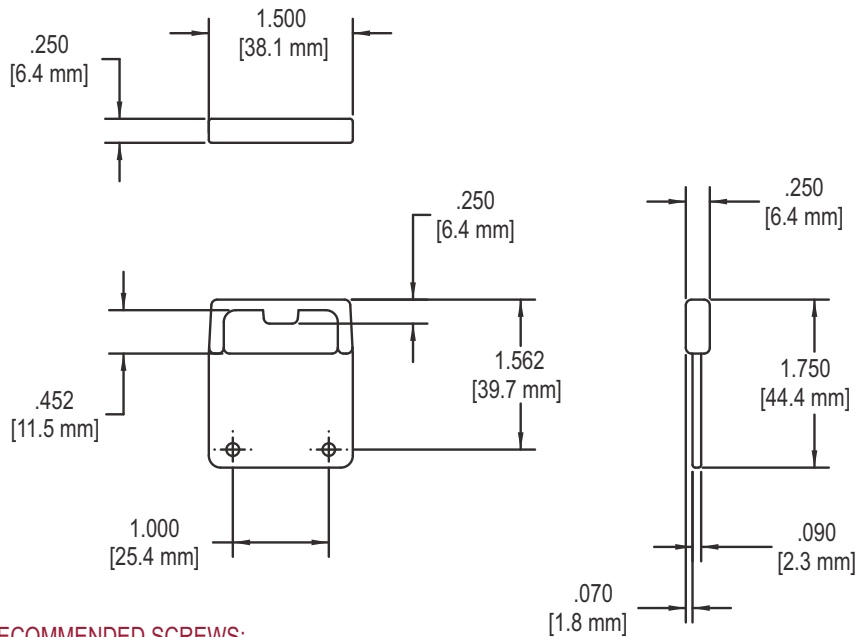

RECOMMENDED SCREWS:

(QTY 2) #6 PHILLIPS PAN HEAD SCREWS. (LENGTH AND THREAD TYPE TO BE DETERMINED BY PROFILE.)

AVAILABLE LOCKS

LOCK PART NUMBER
A09200400
A09200409
A09200411
A09200412
A09200416
A09200417
A09200427
A09200430
A09200441
A09200457
A09200520
A09200580
A09200599

FIG. 17 C09391XX FACE MOUNT KEEPER

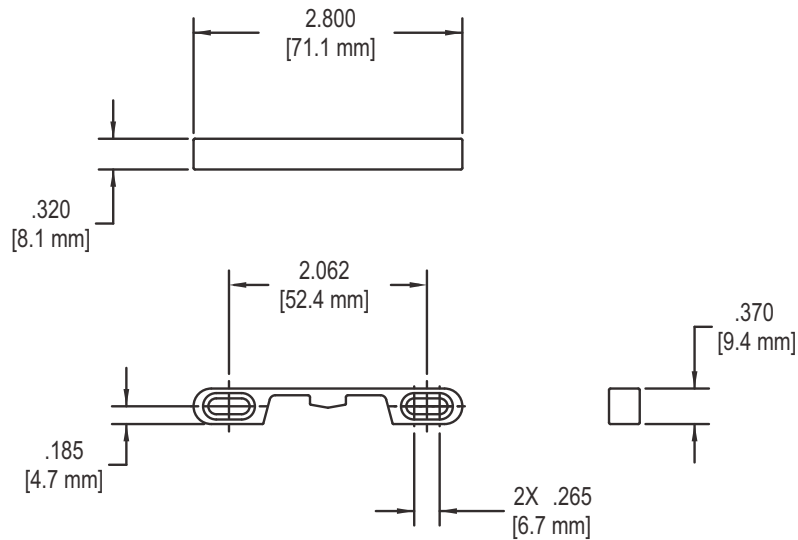

RECOMMENDED SCREWS:

(QTY 2) #6 PHILLIPS FLAT HEAD SCREWS. (LENGTH AND THREAD TYPE TO BE DETERMINED BY PROFILE.)

AVAILABLE LOCKS

LOCK PART NUMBER
A09200400
A09200409
A09200411
A09200412
A09200416
A09200417
A09200427
A09200430
A09200441
A09200457
A09200520
A09200580
A09200599

FIG. 18 C09906XX FACE MOUNT KEEPER

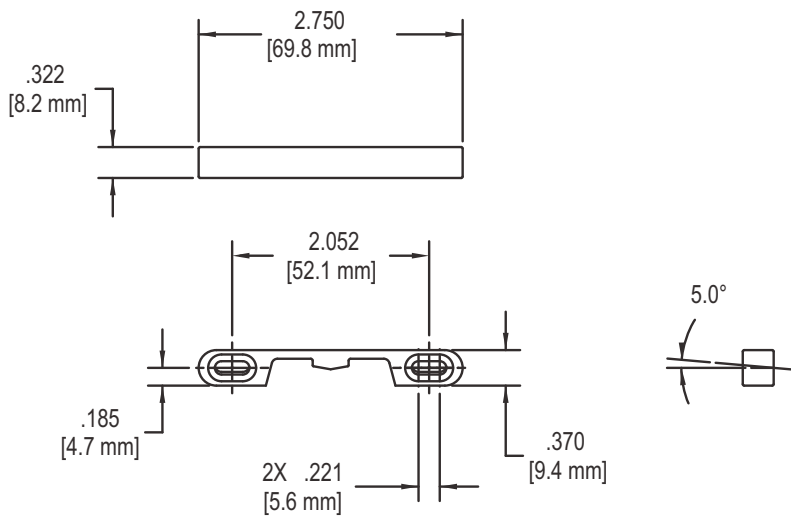

RECOMMENDED SCREWS:

(QTY 2) #6 PHILLIPS FLAT HEAD SCREWS. (LENGTH AND THREAD TYPE TO BE DETERMINED BY PROFILE.)

AVAILABLE LOCKS

LOCK PART NUMBER
A09200400
A09200409
A09200411
A09200412
A09200416
A09200417
A09200427
A09200430
A09200441
A09200457
A09200520
A09200580
A09200599

FIG. 19 41434 FACE MOUNT KEEPER

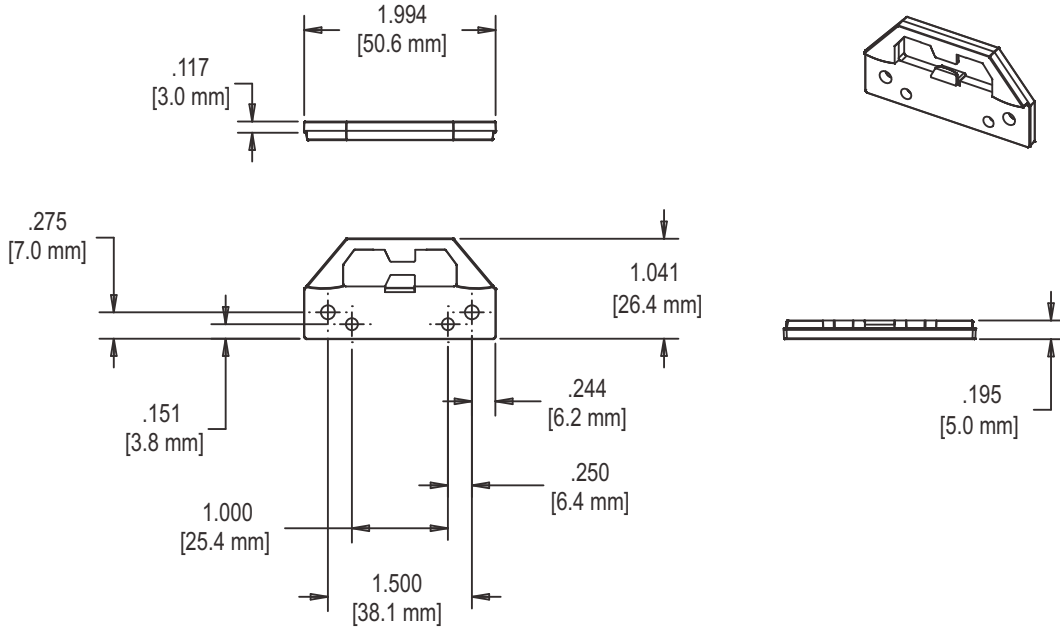
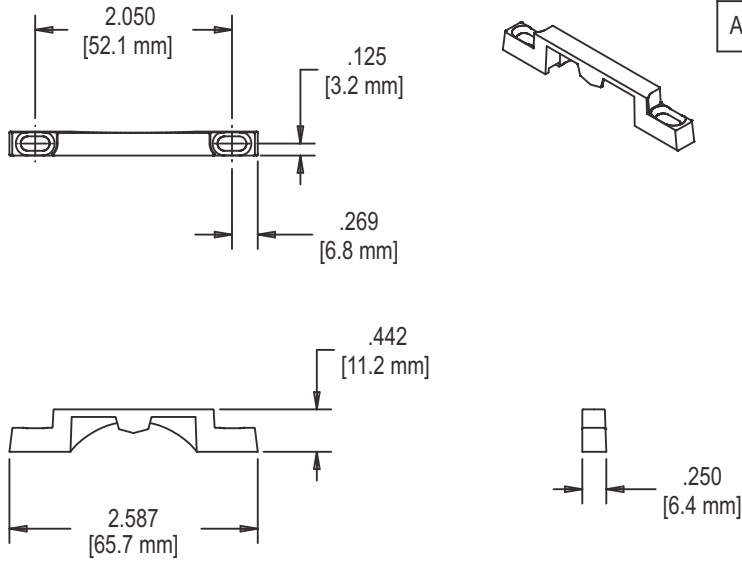

FIG. 20 41405 KEEPER



AVAILABLE LOCKS	A	B
A09200666	.872 (22.1mm)	.060 (1.5mm)

RECOMMENDED SCREWS:

(QTY2) #6 SHEET METAL SCREWS PHILLIPS FLAT HEAD SCREWS
(LENGTH AND THREAD TYPE TO BE DETERMINED BY PROFILE)