

Remove strike plate.

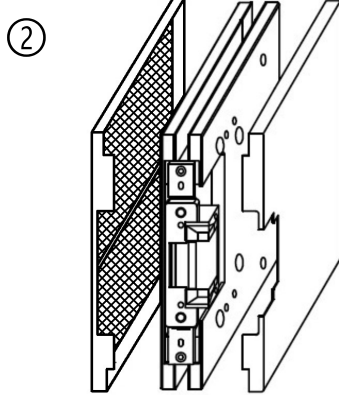

Remove cover plates.

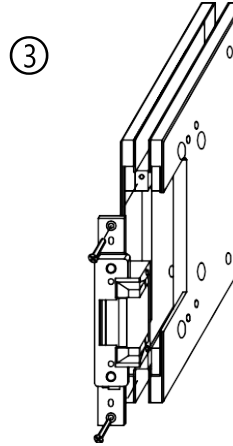

Remove Electric Strike.

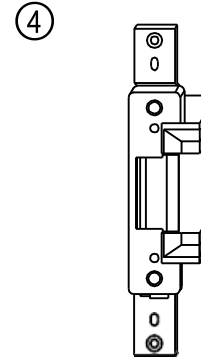

Pre-wire electric strike.  
Per enclosed instructions.

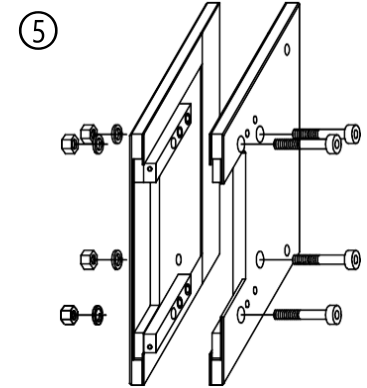

Split clamp plates by  
removing screws.

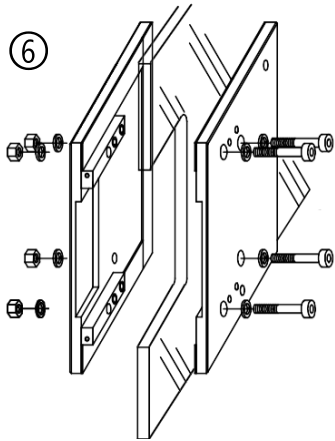

Assemble clamp plates  
onto glass (be sure to  
have nuts and washers  
on the outside).

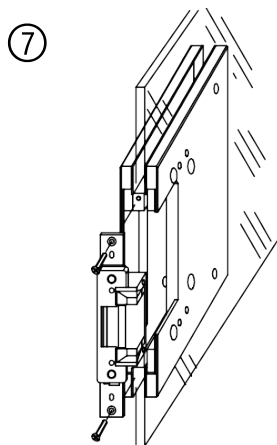

- Re-install electric strike test  
for alignment with lock.  
- Complete wiring.  
- Check strike operation.

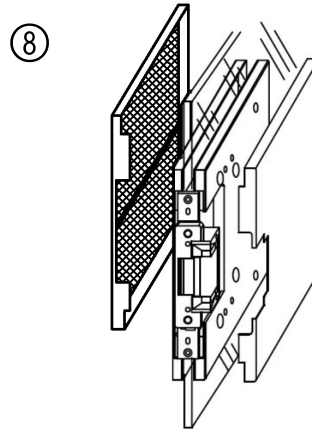

- Remove VHB tape cover paper.  
- Apply cover plates.  
- Press firmly to ensure adhesion.

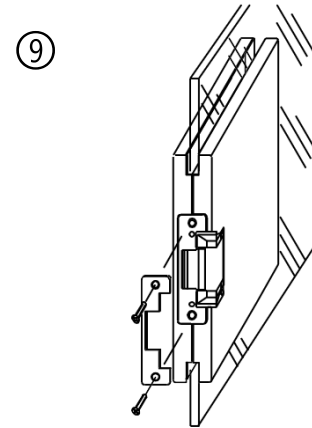

Re-attach strike plate.

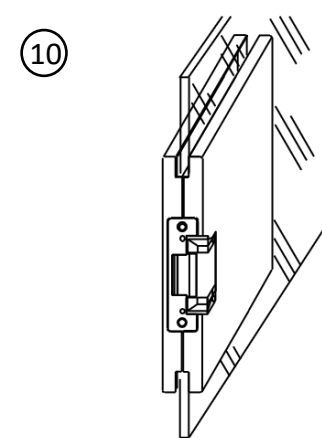

Check strike operation.

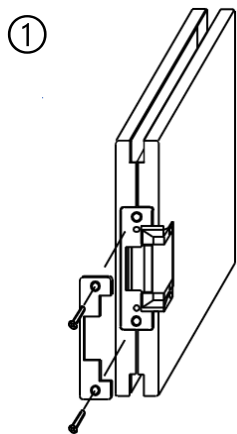

Retirer la gâche.

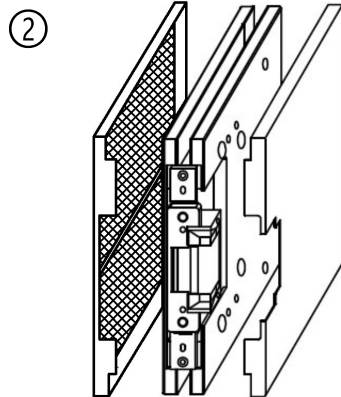

Retirer les plaques de recouvrement.

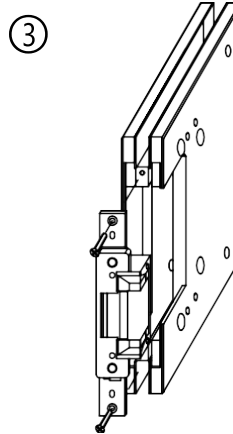

Retirer la gâche électrique.

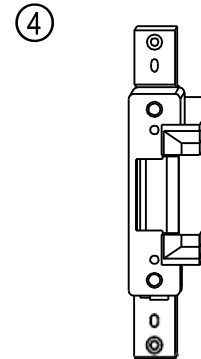

Pré-câbler la gâche électrique. Selon les instructions ci-jointes.

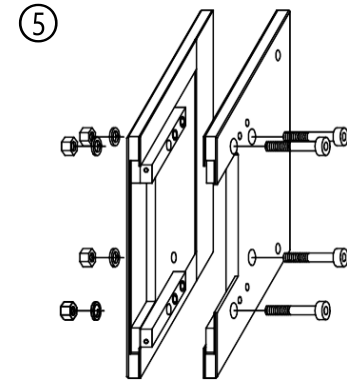

Séparer les pinces en retirant les vis.

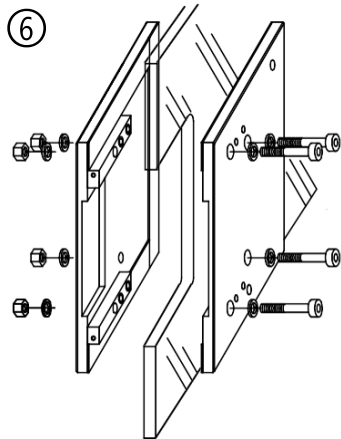

Assembler les pinces de fixation sur le verre. (veiller à ce que les écrous et les rondelles soient placés à l'extérieur).

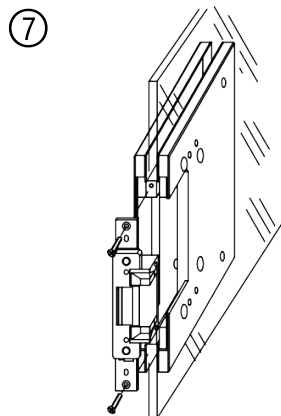

- Réinstaller la gâche électrique, vérifier l'alignement avec la serrure.
- Achever le câblage.
- Vérifier le fonctionnement de la gâche.

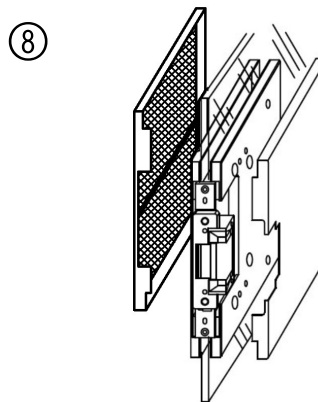

- Retirer le papier de couverture du ruban VHB.
- Appliquer les plaques de recouvrement.
- Appuyer fermement pour assurer l'adhérence.

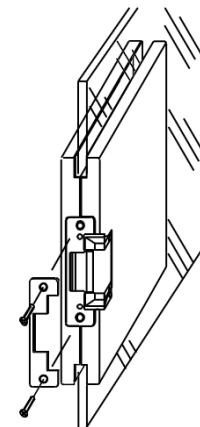

Remettre la gâche en place.

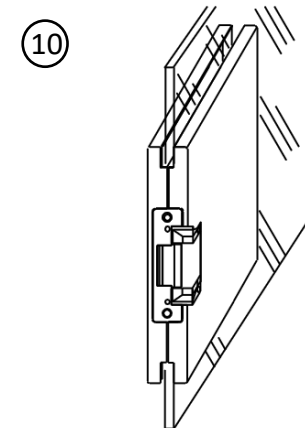

Vérifier le fonctionnement de la gâche.

### Glass Template:

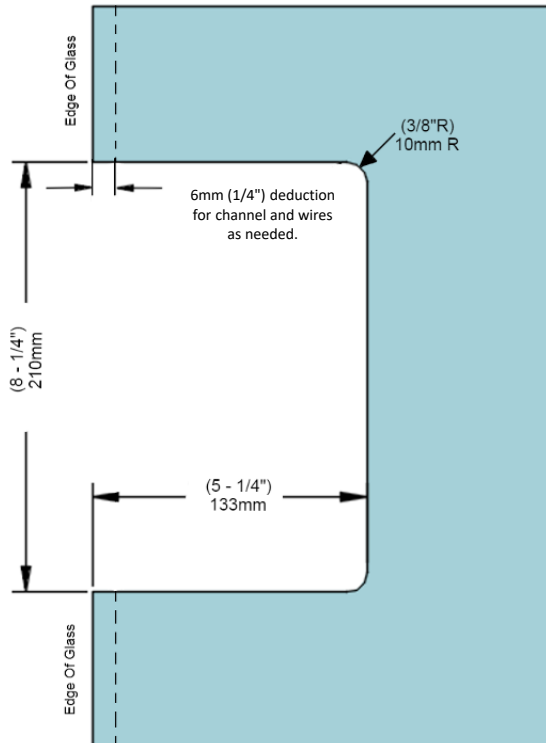

**Center Lock Glass Keeper with  
Electric Strike:** For Office Function.

### Modèle de verre:

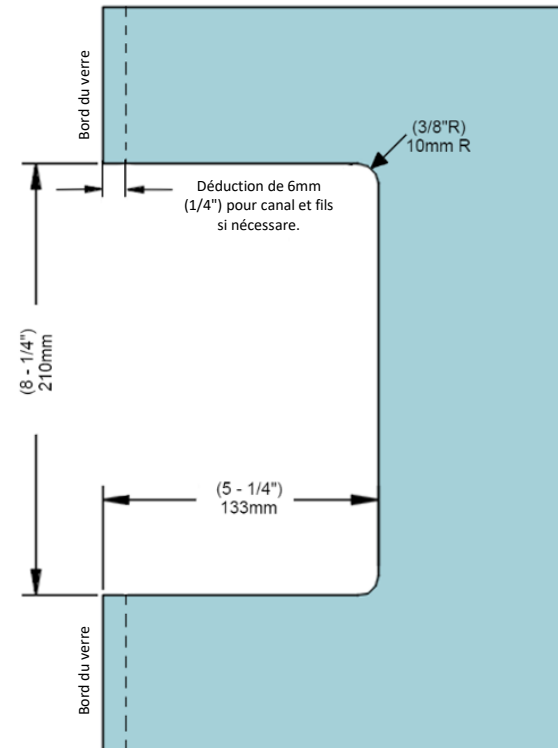

**Gâche pour verre à serrure électrique:**  
Pour la fonction de bureau.