

Installation Instructions for Trim of 336 Series Panic Bar Exit Device (Door with Cylindrical Lock Cut-Out)

Installation Instructions for Trim of 336 Series Panic Bar Exit Device (Door with Cylindrical Lock Cut-Out)

Installation Instructions for Trim of 336 Series Panic Bar Exit Device (Door with Cylindrical Lock Cut-Out)

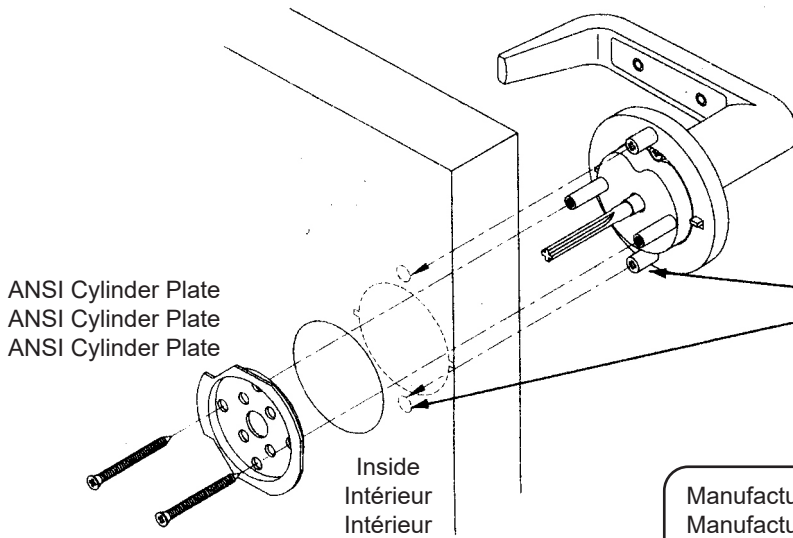

Important! Alignment studs MUST enter into (2) 5/16" field drilled holes on outside of door (existing slots can be elongated with a file)

Important! Alignment studs MUST enter into (2) 5/16" field drilled holes on outside of door (existing slots can be elongated with a file)

Important! Alignment studs MUST enter into (2) 5/16" field drilled holes on outside of door (existing slots can be elongated with a file)

Manufacturer's warranty invalid if security studs are removed.
 Manufacturer's warranty invalid if security studs are removed.
 Manufacturer's warranty invalid if security studs are removed.

For Wood or Metal Doors
 For Wood or Metal Doors
 For Wood or Metal Doors

Drill two 5/16" (8 mm) holes on vertical center line from outside of door.

Drill two 5/16" (8 mm) holes on vertical center line from outside of door.

Drill two 5/16" (8 mm) holes on vertical center line from outside of door.

Fold and align template on edge of door
 Fold and align template on edge of door
 Fold and align template on edge of door

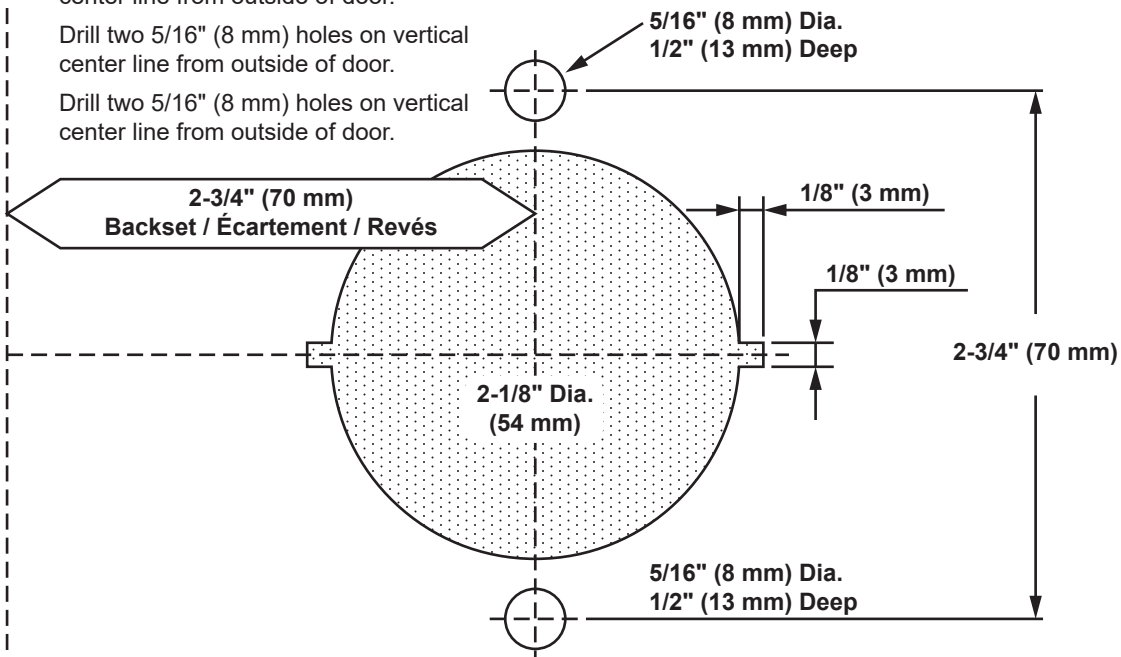

Place template on high edge of bevel
 Place template on high edge of bevel
 Place template on high edge of bevel